

# Q Series™

## Gas Cooling Accessory



## Getting Started Guide



## Notice

The material contained in this manual, and in the online help for the software used to support this instrument, is believed adequate for the intended use of the instrument. If the instrument or procedures are used for purposes other than those specified herein, confirmation of their suitability must be obtained from TA Instruments. Otherwise, TA Instruments does not guarantee any results and assumes no obligation or liability. TA Instruments also reserves the right to revise this document and to make changes without notice.

TA Instruments may have patents, patent applications, trademarks, copyrights, or other intellectual property covering subject matter in this document. Except as expressly provided in written license agreement from TA Instruments, the furnishing of this document does not give you any license to these patents, trademarks, copyrights, or other intellectual property.

TA Instruments Operating Software, as well as Module, Data Analysis, and Utility Software and their associated manuals and online help, are proprietary and copyrighted by TA Instruments. Purchasers are granted a license to use these software programs on the module and controller with which they were purchased. These programs may not be duplicated by the purchaser without the prior written consent of TA Instruments. Each licensed program shall remain the exclusive property of TA Instruments, and no rights or licenses are granted to the purchaser other than as specified above.

TA Instruments can accept no liability for loss or damage, however caused, arising from the faulty or incorrect use of its products. TA Instruments shall not be liable for any damages caused by interactions between exogenous materials (e.g. chemicals) and parts of the instrument. This includes interactions of gaseous, liquid or solid materials with, for instance, ampoule surfaces and/or parts of the instrument. It also includes gases or vapors leaking from ampoules (e.g. originating from chemical reactions producing gaseous substances), with subsequent cause of damage to the calorimeter.

©2013 by  
TA Instruments — Waters LLC  
159 Lukens Drive  
New Castle, DE 19720

# Introduction

## **Important: TA Instruments Manual Supplement**

Please click the [TA Manual Supplement](#) link to access the following important information supplemental to this Getting Started Guide:

- TA Instruments Trademarks
- TA Instruments Patents
- Other Trademarks
- TA Instruments End-User License Agreement
- TA Instruments Offices


## Notes, Cautions, and Warnings

This manual uses NOTES, CAUTIONS, and WARNINGS to emphasize important and critical instructions. In the body of the manual these may be found in the shaded box on the outside of the page.

**NOTE:** A NOTE highlights important information about equipment or procedures.

**CAUTION:** A CAUTION emphasizes a procedure that may damage equipment or cause loss of data if not followed correctly.

**MISE EN GARDE:** UNE MISE EN GARDE met l'accent sur une procédure susceptible d'endommager l'équipement ou de causer la perte des données si elle n'est pas correctement suivie.

	<p><b>A WARNING indicates a procedure that may be hazardous to the operator or to the environment if not followed correctly.</b></p> <p><b>Un AVERTISSEMENT indique une procédure qui peut être dangereuse pour l'opérateur ou l'environnement si elle n'est pas correctement suivie.</b></p>
-----------------------------------------------------------------------------------	-----------------------------------------------------------------------------------------------------------------------------------------------------------------------------------------------------------------------------------------------------------------------------------------------

## Regulatory Compliance

### *Safety Standards*

#### **For Canada**

CAN/CSA-C22.2 No. 61010-1 Safety requirements for electrical equipment for measurement, control, and laboratory use, Part 1: General Requirements.

CAN/CSA-C22.2 No. 61010-2-010 Particular requirements for laboratory equipment for the heating of materials.

#### **For European Economic Area**

(In accordance with Council Directive 2006/95/EC of 12 December 2006 on the harmonization of the laws of Member States relating to electrical equipment designed for use within certain voltage limits.)

EN 61010-1:2001 Safety requirements for electrical equipment for measurement, control, and laboratory use, Part 1: General Requirements + Amendments.

EN 61010-2-010:2003 Particular requirements for laboratory equipment for the heating of materials + Amendments.

#### **For United States**

UL61010-1:2004 Electrical Equipment for Laboratory Use; Part 1: General Requirements.

# Electromagnetic Compatibility Standards

## For Australia and New Zealand

AS/NZS CISPR11:2004 Limits and methods of measurement of electronic disturbance characteristics of industrial, scientific and medical (ISM) radio frequency equipment.

## For Canada

ICES-001 Issue 4 June 2006 Interference-Causing Equipment Standard: Industrial, Scientific, and Medical Radio Frequency Generators.

## For the European Economic Area

(In accordance with Council Directive 2004/108/EC of 15 December 2004 on the approximation of the laws of the Member States relating to electromagnetic compatibility.)

EN61326-1:2006 Electrical equipment for measurement, control, and laboratory use-EMC requirements-Part 1: General Requirements. Emissions: Meets Class A requirements per CISPR 11. Immunity: Per Table 1 - Basic immunity test requirements.

## For the United States

CFR Title 47 Telecommunication Chapter I Federal Communications Commission, Part 15 Radio frequency devices (FCC regulation pertaining to radio frequency emissions).

## Safety



**WARNING: The operator of this accessory is advised that if the equipment is used in a manner not specified in this manual, the protection provided by the equipment may be impaired.**

**AVERTISSEMENT: L'utilisateur de cet accessoire est prévenu qu'en cas d'utilisation contraire aux indications du manuel, la protection offerte par l'équipement peut être altérée.**


There are several major areas of concern pertaining to personal safety when using the Gas Cooling Accessory. Please refer to the sections below.

## *Required Equipment*

While operating this accessory, you must wear eye protection that either meets or exceeds ANSI Z87.1 standards. Additionally, wear protective clothing that has been approved for protection against the materials under test and the test temperatures.


## Accessory Symbols

The following label is displayed on the GCA for your protection:

Symbol	Explanation
	<p>This symbol indicates that you should read this Getting Started Guide in its entirety. This guide contains important warnings and cautions related to the installation, operation, and safety of the accessory.</p> <p>Ce symbole indique que vous devez lire entièrement ce guide de démarrage. Ce guide contient d'importants avertissements et mises en garde relatifs à l'installation, à l'utilisation et à la sécurité de l'accessoire.</p>

Please heed the warning labels and take the necessary precautions when dealing with these areas. The *Q Series™ Gas Cooling Accessory Getting Started Guide* contains cautions and warnings that must be followed for your own safety.

## Handling Liquid Nitrogen

	<p><b>WARNING: Safe Handling of Cryogenic Materials</b></p> <p>Liquid nitrogen is used as a cooling agent in many thermal analysis tests. Because of its extremely low temperature (-196°C) it will burn skin. You must use extreme care when working with liquid nitrogen or other cryogenic materials.</p> <p><b>Liquid Nitrogen Can:</b></p> <ol style="list-style-type: none"><li>1. Cause serious skin burns</li><li>2. Replace the air in the room you are in</li><li>3. Generate very high pressures if trapped in lines or containers.</li></ol>
	<p><b>AVERTISSEMENT: Manipulation sécurisée des matières cryogéniques</b></p> <p>L'azote liquide est utilisé comme agent de refroidissement dans de nombreux essais d'analyse thermique. À cause de sa température extrêmement basse (-196°C), il peut brûler la peau. Vous devez être extrêmement prudent lorsque vous travaillez avec de l'azote liquide ou d'autres matières cryogéniques.</p> <p><b>L'azote liquide peut:</b></p> <ol style="list-style-type: none"><li>1. provoquer des brûlures de la peau</li><li>2. remplacer l'air de la pièce dans laquelle vous vous trouvez</li><li>3. produire des pressions très élevées s'il est piégé dans les conduites ou les cuves.</li></ol>

The DMA uses liquid nitrogen as a source of cold gas in the Gas Cooling Accessory (GCA). Because of its low temperature [-195°C (-319°F)], liquid nitrogen will burn the skin. When you work with liquid nitrogen, use the following precautions:



**WARNING: Liquid nitrogen boils rapidly when exposed to room temperature. Be certain that areas where liquid nitrogen is used are well ventilated to prevent displacement of oxygen in the air.**

**AVERTISSEMENT: L'azote liquide bout rapidement lorsqu'il est exposé à la température ambiante. Assurez-vous que les zones où l'azote liquide est utilisé sont bien aérées pour éviter le déplacement de l'oxygène dans l'air.**

- 1 Wear goggles or a face shield, gloves large enough to be removed easily, and a rubber apron. For extra protection, wear high-topped, sturdy shoes, and leave your pant legs outside the tops.
- 2 Transfer the liquid slowly to prevent thermal shock to the equipment. Use containers that have satisfactory low-temperature properties. Ensure that closed containers have vents to relieve pressure.
- 3 The purity of liquid nitrogen decreases when exposed to air. If the liquid in a container has been open to the atmosphere for a prolonged period, analyze the remaining liquid before using it for any purpose where high oxygen content could be dangerous.

**WARNING:  
Potential Asphyxiant**

Liquid nitrogen can cause rapid suffocation without warning.

Store and use in an area with adequate ventilation.

Do not vent the Gas Cooling Accessory (GCA) in confined spaces.

Do not enter confined spaces where nitrogen gas may be present unless the area is well ventilated.

**AVERTISSEMENT:  
Asphyxiant potentiel**

L'azote liquide peut provoquer un étouffement rapide sans prévenir.

Entreposez-le et utilisez-le dans une zone bien aérée.

N'aérez pas le récipient accessoire de refroidissement de gaz (GCA) dans des espaces confinés.

N'entrez pas dans des espaces confinés où l'azote gazeux peut être présent à moins que la zone soit bien aérée.

The Potential Asphyxiant warning applies to the use of liquid nitrogen. Oxygen depletion sensors are sometimes utilized where liquid nitrogen is in use.

## Room Ventilation

Liquid Nitrogen evaporates quickly at room temperature and could replace the air in a room. Only use liquid nitrogen in a well-ventilated room. Important—see the Warning above.

## Oxygen Absorption

Liquid Nitrogen will absorb oxygen from the air. It is possible for the purity of liquid nitrogen to change as it evaporates from a container. If you suspect a lot of liquid nitrogen has evaporated the remaining liquid should be analyzed for oxygen content before using if for any purpose where high oxygen content is dangerous.

## Pressure Buildup

Liquid Nitrogen should not be stored in a sealed container, as tremendous pressure could result and an explosion is possible.

The GCA is designed to always be vented to the room when not supplying nitrogen gas to the test instrument. The pressure build up in the GCA, when it is supplying nitrogen gas to the instrument, is limited by the controller. Pressure relief valves are also designed into the system.

If the feed line pressure relief valve is venting, either the bulk storage tank pressure is too high, or the bulk storage tank valve has been closed, trapping liquid nitrogen in the feed tube. Verify that gas is flowing through the vent and coolant feed valve before continuing normal operation by running the following method:

- 1 Jump to  $-50^{\circ}\text{C}$
  - 2 Isothermal for 1 min.
- While the method is running vapor should be coming from the DMA furnace assembly. If no vapor is apparent, stop the method and check the coolant transfer tube for blockage. If no blockage is found, call TA Instruments for service. If a blockage is found, clear it and run the method again.
  - When the method has completed, you should hear gas venting from the GCA. If you do not hear the gas venting, call TA Instruments for service.



**WARNING: Always make sure the GCA system is installed correctly. Make sure the fill line from the bulk storage tank is hooked up properly.**

**AVERTISSEMENT: Assurez-vous toujours que le système GCA est correctement installé. Assurez-vous que la conduite de remplissage du réservoir de stockage en vrac est correctement connectée.**



**CAUTION: Never allow liquid nitrogen to be trapped in the fill line from the bulk storage tank to the GCA.**

**MISE EN GARDE: Ne laissez jamais l'azote liquide coincé dans la conduite de remplissage entre le réservoir de stockage en vrac et le GCA.**



**WARNING: Do not use high pressure bulk tanks [greater than 170 kPa gauge (25 psig)]. The GCA is designed for lower pressure bulk tanks. Using high pressure tanks will cause the GCA to work improperly and raise the potential for injury.**

**AVERTISSEMENT: N'utilisez pas de réservoir en vrac haute pression supérieur à 170 kPa (pression manométrique) (25 psig)]. Le GCA est conçu pour les réservoir en vrac basse pression L'utilisation de réservoirs en vrac haute pression entraîne le fonctionnement inapproprié du GCA et augmente le risque de blessures.**

The sequence for opening and closing valves is important to prevent trapping liquid nitrogen in the fill tube. When the bulk storage feed tube is connected for autofilling, it is important that you do not ever close the manual valve on the bulk storage tank, unless the bulk storage tank is empty, or at least 15 minutes has elapsed since the solenoid valve at the GCA has closed. (The solenoid valve closes at the end of Autofill.) This time allows the liquid nitrogen to vaporize before sealing the area between the solenoid valve and the valve on the bulk storage tank.

**CAUTION: Never remove the GCA Autofill line at the bulk storage tank without closing the bulk storage tank valve first.**

**MISE EN GARDE: Ne retirez jamais la conduite de remplissage automatique du GCA du réservoir de stockage en vrac sans fermer la vanne du réservoir d'abord.**

When connecting and removing the GCA Autofill line remember to wear goggles and gloves.



**WARNING: Do not use high pressure bulk tanks [greater than 170 kPa gauge (25 psig)]. The GCA is designed for lower pressure bulk tanks. Using high pressure tanks will cause the GCA to work improperly and raise the potential for injury.**

**AVERTISSEMENT: N'utilisez pas de réservoir en vrac haute pression supérieur à 170 kPa (pression manométrique) (25 psig)]. Le GCA est conçu pour les réservoir en vrac basse pression L'utilisation de réservoirs en vrac haute pression entraîne le fonctionnement inapproprié du GCA et augmente le risque de blessures.**

### ***Water Condensation***

The GCA surfaces get cold during use of the GCA for both filling and supplying cold nitrogen to the instrument. The cold surfaces cause condensation and, in some cases, frost to build up. This condensation may drip to the floor. Provisions to keep the floor dry should be made. If any moisture does drip to the floor, be sure to clean it up promptly to prevent a slipping hazard.

## ***Electrical Safety***

High voltages (120 Vac) are present in this instrument, only qualified service personnel should remove covers and make repairs.



**WARNING: The power at the instrument *must* be turned off, and the interface cable and power cord must be removed before any service or repair work is started.**

**AVERTISSEMENT: L'alimentation de l'instrument doit être coupée, le câble d'interface et le cordon d'alimentation doivent être retirés avant le démarrage des travaux de réparation ou d'entretien.**



**WARNING: Hazardous voltage is present inside the GCA. Do not remove the clamp securing the cap to the dewar. There are no user-serviceable parts inside the GCA. Call TA Instruments for service.**

**AVERTISSEMENT: Présence d'une tension dangereuse dans le GCA. Ne retirez pas la bride de serrage qui maintient le bouchon au Dewar. Le GCA ne contient aucune pièce remplaçable par l'utilisateur. Appelez TA Instruments pour l'entretien.**

## ***Lifting the Instrument***

The GCA is a fairly heavy accessory. In order to avoid injury, particularly to the back, please follow this advice:



**WARNING: Roll the GCA on its wheels to move it, whenever possible. If you must lift it, use two people to lift and/or carry the instrument. The instrument is too heavy for one person to handle safely.**

**AVERTISSEMENT: Faites rouler le GCA sur ses roulettes pour le déplacer, si possible. Si vous devez le soulever, demandez à deux personnes de soulever et/ou de porter l'instrument. L'instrument est trop lourd pour qu'une seule personne le manipule en toute sécurité.**

# Table of Contents

<b>Introduction.....</b>	<b>3</b>
Important: TA Instruments Manual Supplement .....	3
Notes, Cautions, and Warnings.....	4
Regulatory Compliance.....	4
Safety Standards .....	4
Electromagnetic Compatibility Standards.....	5
Safety.....	5
Required Equipment .....	5
Accessory Symbols.....	6
Handling Liquid Nitrogen .....	6
<b>Table of Contents.....</b>	<b>10</b>
<b>Introducing the GCA.....</b>	<b>12</b>
Overview	12
Instrument Specifications	13
Theory of Operation	14
Description of Components	15
Top Section of GCA.....	16
<b>Installing the GCA.....</b>	<b>19</b>
Unpacking and Inspecting	19
Before Installation	19
Choosing a Location .....	19
In.....	19
Near .....	20
Away from.....	20
Installing the GCA	20
Installing the GCA for use with a DMA .....	20
Updating the GCA Software with the DMA	24
Installing the GCA for use with the DHR or AR Rheometer EHP System	24
Installing the Drain Valve	28
<b>Operating and Maintaining the GCA.....</b>	<b>30</b>
Overview	30
Autofilling the GCA	30
Autofilling the GCA for the First Time (DMA) .....	31
Refilling the GCA After a DMA Experiment.....	31
Autofilling the GCA for the First Time (Rheometer) .....	31
Refilling the GCA after a Rheometer Experiment.....	32

Manually Filling the GCA 32

Operating Your GCA with the DMA 34  
    Basic Operation..... 34

Maintaining the GCA 34  
    Cleaning the GCA ..... 35  
    Replacing the Fuses..... 35  
    Replacement Parts ..... 36

**Index..... 37**

# Chapter 1:

## Introducing the GCA

---

### Overview

The GCA (Gas Cooling Accessory) is a cooling accessory for use with the TA Instruments Dynamic Mechanical Analyzer (DMA) or with the DHR Series/AR-G2/ AR 200ex/AR 1500ex Rheometer Electrically Heated Plates (EHP). The GCA has been designed for automatic refilling from a low pressure [170 kPa gauge (25 psig) maximum] bulk storage tank that can be located within 1.8 meters (6 feet) of the GCA.

The GCA is also capable of being filled manually by disconnecting it from the instrument and moving it to a bulk storage source.



**Figure 1** Gas Cooling Accessory.

**NOTE:** Before proceeding, be sure you understand and follow the safety precautions in the prefix of this manual.

## Instrument Specifications

The specifications in the following tables apply to the Gas Cooling Accessory.

**Table 1: GCA Technical Specifications**

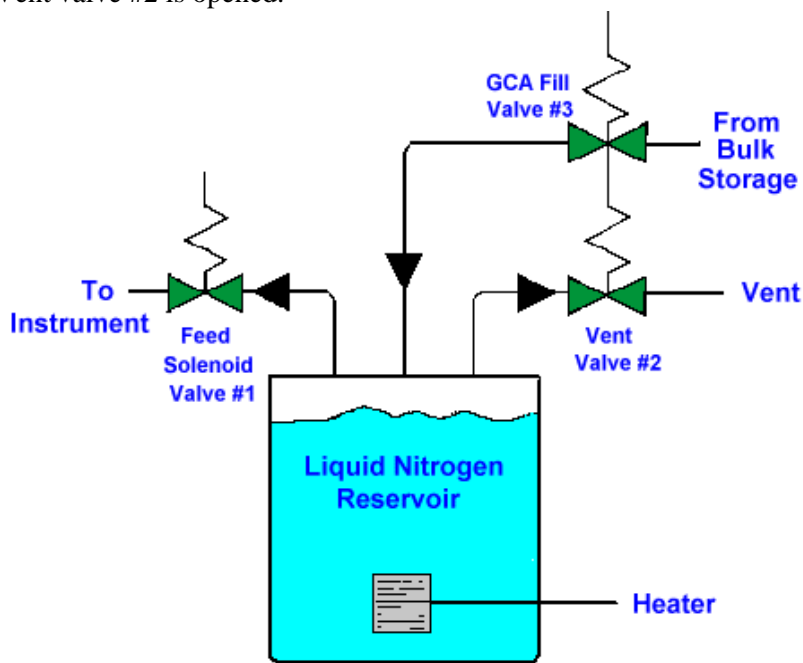
Item/Area	Specification
Liquid nitrogen capacity	50 L
Size	107 cm (42 in) high 46cm (18 in) diameter of dewar 79cm (31 in) diameter of feet
Weight	46 kg (101 lbs) empty 87 kg (191 lbs) full
Power requirements	120 Vac at 0.9 kVa, 47–63 Hz
Cooling capacity	–145°C (DMA), –70°C (EHP)
Pressure relief	90 kPa gauge (13 psig) relief valve on tank 345 kPa gauge (50 psig) on fill line
Liquid nitrogen tubes	Transfer: 1.8 meters (6 feet) insulated from GCA to instrument.
GCA fill modes	Automatic: Bulk storage within 1.8 meters (6 feet) of GCA. Manual: Remote filling at bulk storage location.
Bulk storage tank	Use low pressure supply tank only. Recommended filling pressure is 140 to 170 kPa gauge (20 to 25 psig)
Operating environment conditions	Temperature: 15–30 °C Conditions Relative Humidity: 5–80% (non-condensing) Installation Category II Pollution Degree 2 Maximum Altitude: 2000 m  <b>NOTE:</b> The GCA vents to the atmosphere, if no filling or testing is currently in progress.

# Theory of Operation

The GCA uses up to eight selectively switched 100-W heaters to vaporize the liquid nitrogen and obtain required pressures of up to 62 kPa gauge (9 psig). The pressurized gas is forced out of the tank and into the DMA furnace assembly. The number of heaters that are turned on depend on the cooling rate desired.

The operation of the GCA is very simple. When cooling gas is needed by the instrument, the following events occur (refer to the figure below for an illustration of the numbered parts):

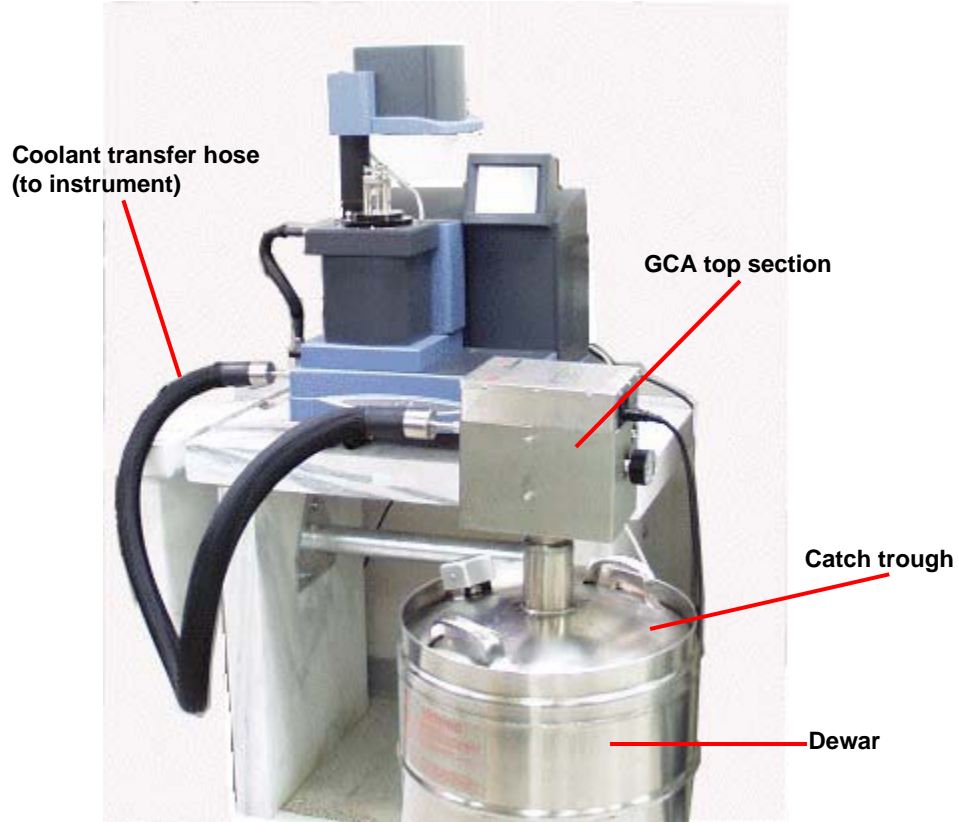
- 1 Instrument requests cooling gas.
  - 1 Heater in the GCA is turned on.
  - 2 Feed solenoid valve #1 opens.
  - 3 Vent valve #2 is closed.
- 2 Instrument no longer requests coolant.
  - 1 Heater in the GCA is turned off.
  - 2 Feed Solenoid valve #1 closes.
  - 3 Vent valve #2 is opened.



**Figure 2** GCA operation illustration.

## *Description of Components*

The following illustration shows the major parts of the TA Instruments GCA as it appears when connected to a DMA Q800. The major parts of the GCA are the dewar, which holds the liquid nitrogen; the coolant transfer and feed hoses, which connect to the instrument and bulk liquid nitrogen source respectively; and the top section, which contains all of the ports and valves needed to make the connections.

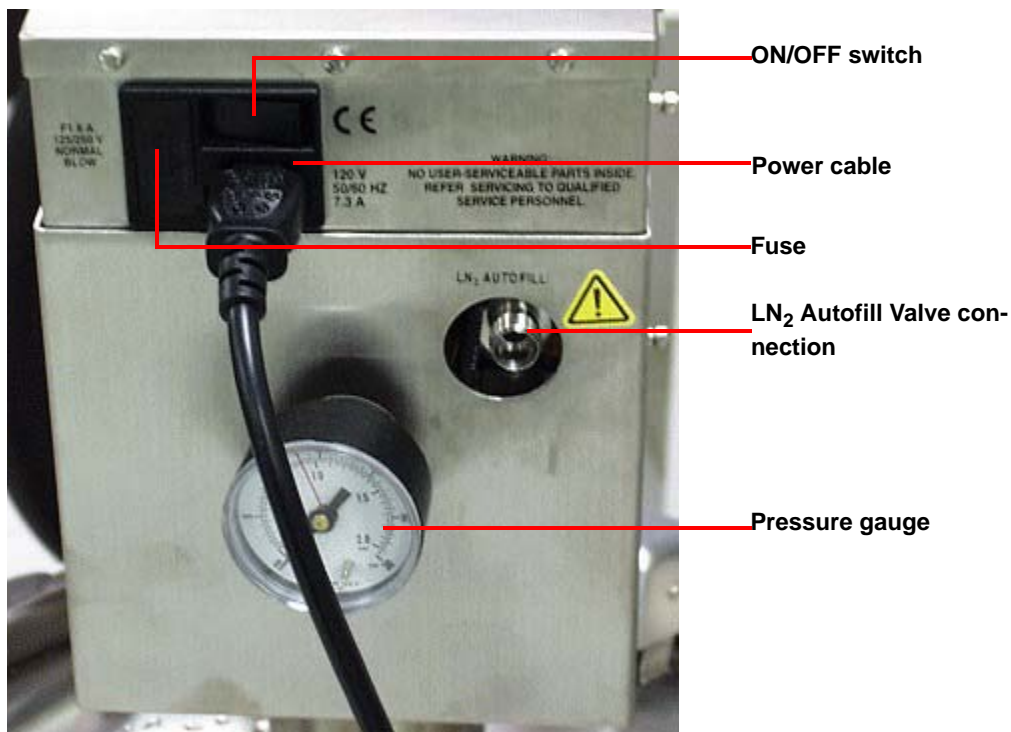
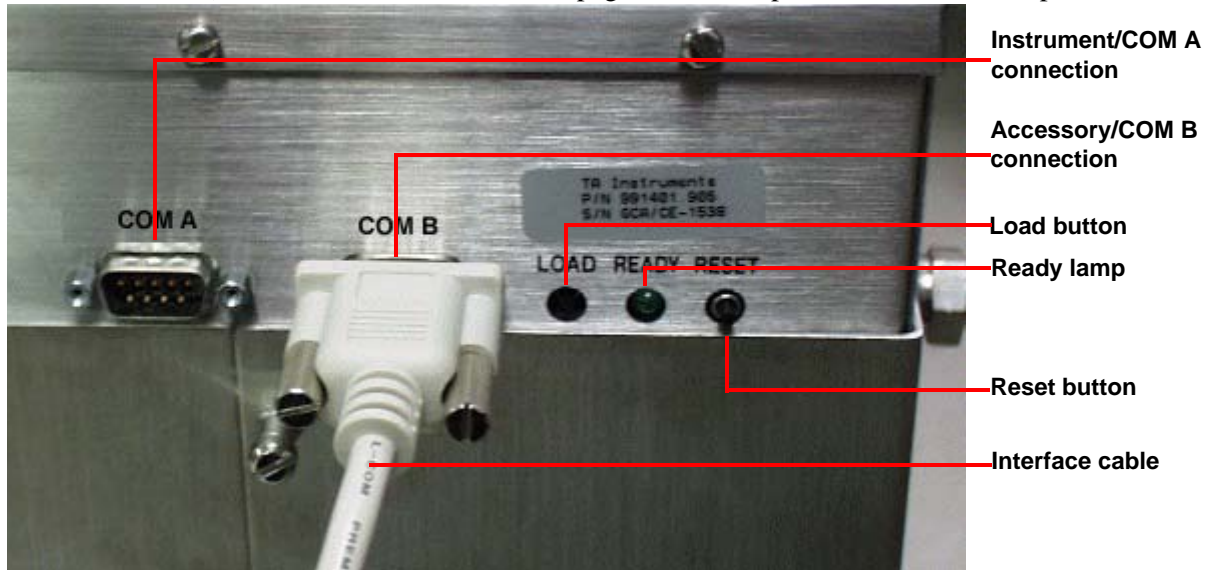


**Figure 3** Major GCA components.

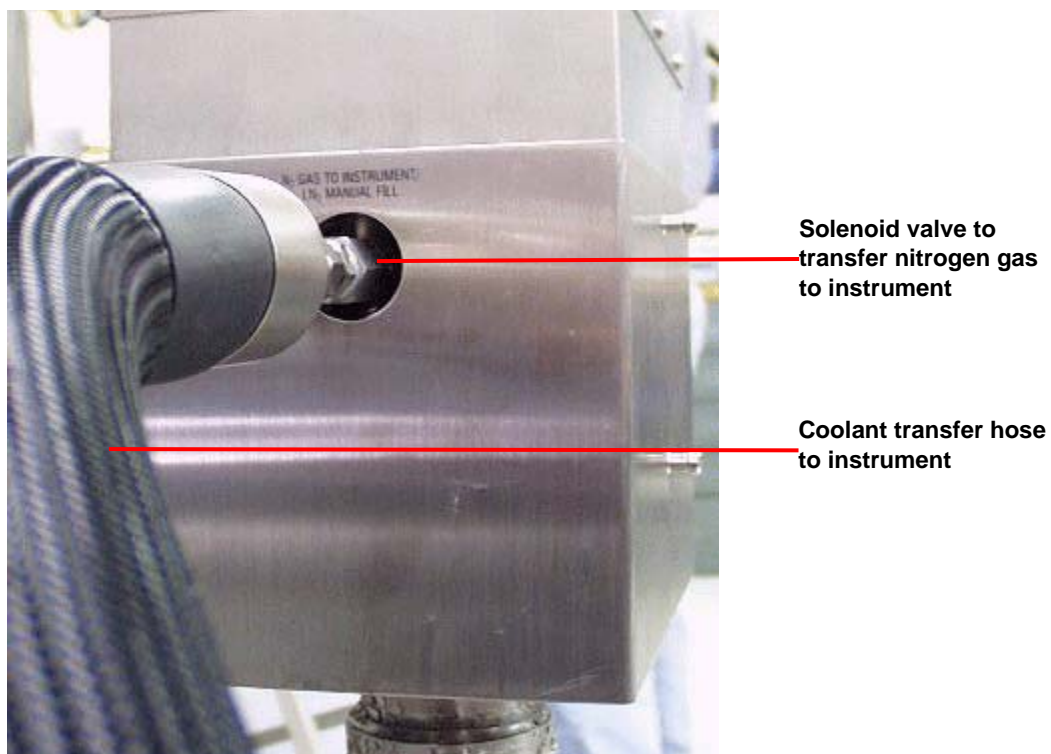


## Top Section of GCA

The top section of the GCA contains several items important to the operation of the accessory and the instrument. The figures below and on the next page illustrate the items found on sides of the GCA top section. (NOTE: The labeling of the GCA ports on the top section of your unit may vary slightly from the figure shown below.) Refer to the table on the next page for a description of the individual parts.



**Figure 4** GCA top section.



**Figure 5** GCA top section.

**Table 2: GCA Parts**

Item/Area	Description
50 liter dewar	The thermally-insulated storage vessel for liquid nitrogen.
Coolant transfer hose	Supplies gaseous nitrogen from the GCA to the instrument.
Catch trough	Recessed area that allows condensation to collect on the top of the dewar. The resulting water can be released via a drain valve. See Chapter 2 for instructions.
Interface cable	Provides the control signals from the instrument to the GCA.
Instrument/COM A connection	<i>For the DMA Q800:</i> Connects the GCA to any accessories. <i>For the DMA 2980:</i> Connects the GCA with the instrument to communicate information such as GCA tank pressure, heater regulation, etc. between the GCA and the instrument.

Item/Area	Description
Accessory/COM B connection	<p><i>For the DMA Q800:</i> Connects the GCA with the instrument to communicate information such as GCA tank pressure, heater regulation, etc. between the GCA and the instrument.</p> <p><i>For the DMA 2980:</i> Connects the GCA to any accessories such as the Gas Switching Accessory.</p>
Load button	Used to place the GCA in load mode to load software. See the DMA online help for instructions.
Ready lamp	Glows when the GCA has finished its confidence test and is ready for operation with the instrument. If this lamp blinks, it signals a fatal error during the confidence test—call TA Instruments for service.
Reset button	Press to reset the GCA and run the confidence test again.
ON/OFF switch	Turns the GCA power on. This switch must be on for the GCA to supply coolant to the instrument and to refill the GCA automatically from the bulk liquid nitrogen storage container.
Fuse	An 8A, 125/250V normal blow fuse is located in the top section of the GCA. If this fuse blows, you will get no response from the unit when you attempt to turn it on.
Power cable	Plugs into a source of electrical power to provide power for the operation of the GCA and its heaters.
LN <sub>2</sub> Autofill Valve connection	Connect the GCA feed tube from this valve to supply liquid nitrogen from the bulk source to the GCA.
Pressure gauge	Provides a reading on the pressure contained within the dewar. This gauge should measure less than 90 kPa gauge (13 psig). The red line indicates the pressure at which the relief valve actuates.
Solenoid transfer valve	An automatic solenoid valve that opens to supply gaseous nitrogen to the instrument.
Bulk storage feed hose (not shown)	Allows the automatic and manual filling of the 50 L GCA dewar from a bulk storage source.

# Chapter 2:

## Installing the GCA

---

### *Unpacking and Inspecting*

By the time you are reading this manual, you have already done a certain amount of unpacking. Continue to unpack and inspect the contents of the GCA shipping box. Retain the shipping container and packing materials until the unit has been successfully installed and verified to be functioning correctly.

If the GCA received rough handling in shipment and signs of damage are apparent, contact the carrier immediately for advice on how to make a claim. Please call TA Instruments to advise us of the problem. DO NOT use or install the instrument until an authorized representative of TA Instruments has repaired it.

Contact your TA Instruments representative if parts are missing.

### *Before Installation*

There are a few items to check before you begin installing the GCA to the instrument. Please check the following:



**WARNING: Read the safety precautions for handling cryogenic materials (located in the prefix of this manual) before installing the GCA. Wear goggles or a face shield and gloves large enough to be removed easily whenever you handle liquid nitrogen.**

**AVERTISSEMENT: Lisez les précautions de sécurité à prendre lors de la manipulation des matières cryogéniques (disponibles dans le préfixe du présent manuel avant d'installer le GCA. Portez des lunettes de protection ou un écran facial et des gants assez grands pour être retirés facilement chaque fois que vous manipulez de l'azote liquide.**

- Check the clamp holding the GCA top section to the dewar. The clamp is located below the sheet metal covers. The clamp must be tight for proper operation of the equipment.
- Connecting the GCA to an instrument requires that a specific interface cable be used. Make sure the proper cable is being used for this installation.

## Choosing a Location

Because of the sensitivity of experiments using the GCA, it is important to choose a location using the following guidelines. The GCA should be:

### *In*

- a temperature-controlled area.
- a clean environment.
- an area with ample working and ventilation space around the instrument. (Refer to the technical specifications in Chapter 1 for the instrument's dimensions.)

### *Near*

- a power outlet (120 Vac, 50 or 60 Hz, 10 amps). A step up/down line transformer may be required if the unit is operated from a higher or lower line voltage.
- your TA Instruments DMA.

### *Away from*

- dusty environments.
- exposure to direct sunlight.
- direct air drafts (fans, room air ducts).
- poorly ventilated areas.

After you have decided on the location for your instrument and GCA, refer to the next several sections to unpack and install the GCA.

## *Installing the GCA*

The GCA can be connected to either a DMA or an AR Rheometer with EHP system. Follow the instructions appropriate to your instrument.

### **Installing the GCA for use with a DMA**

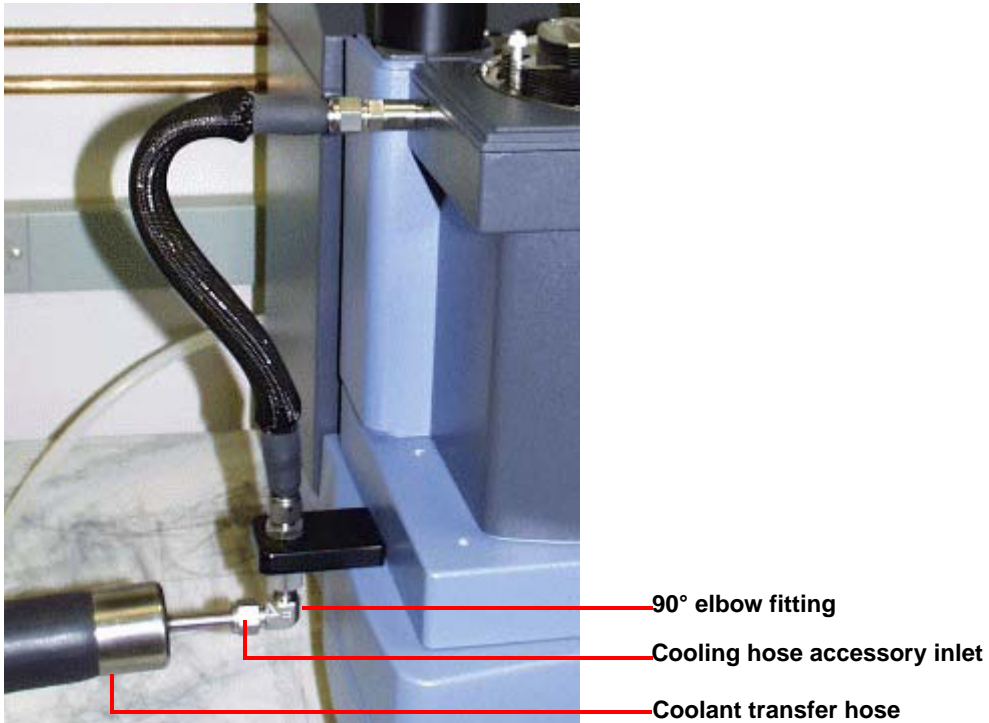
Installing the GCA primarily consists of connecting the interface cable and attaching the coolant transfer hose to the bulk liquid nitrogen source. Use the following basic steps to install the GCA.

- 1 Position the GCA within 1.8 meters (6 feet) of the instrument.
- 2 Attach the coolant transfer hose to the GCA at the fitting labeled **N<sub>2</sub> Gas to Instrument/LN<sub>2</sub> Manual Fill**.

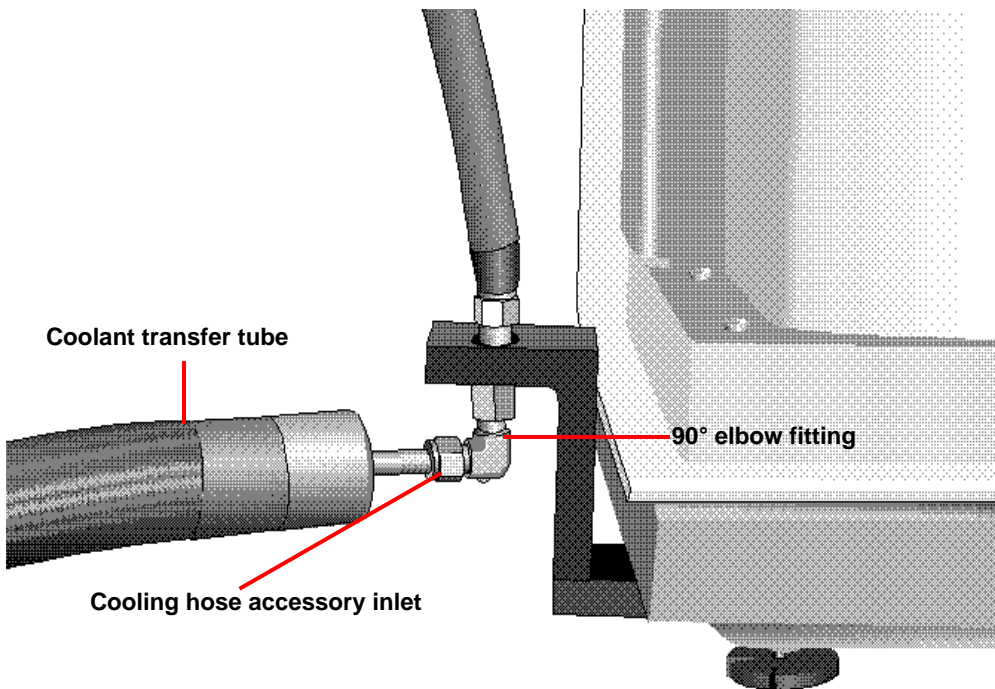


**Figure 6** Coolant transfer hose attached to the GCA.

- 3 Remove the air cool line (if present) from the 90° elbow fitting on the DMA, and attach the coolant transfer hose to the DMA. See the figures below for the instrument you are using. See [Figure 7](#) for the DMA Q800 configuration and [Figure 8](#) for the DMA 2980 configuration. Make sure the fittings are tight.




**Figure 7** Connecting the coolant transfer tube to the DMA Q800.



**Figure 8** Connecting the coolant transfer tube to the DMA 2980.

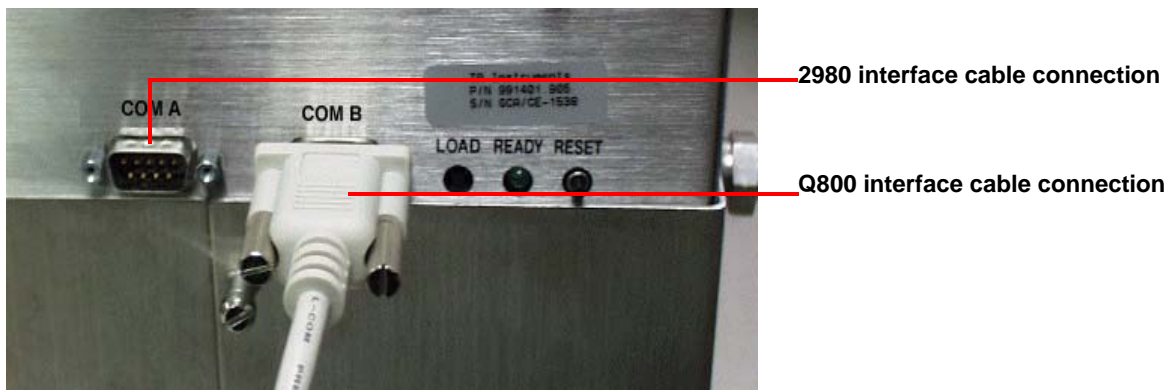
- 4 Make sure the power switch on the GCA is in the OFF position.

	<p><b>WARNING: The instrument power switch should be OFF before connections are made.</b></p> <p><b>AVERTISSEMENT: Avant d'effectuer les raccordements, l'interrupteur d'alimentation de l'instrument doit être à l'arrêt.</b></p>
-----------------------------------------------------------------------------------	------------------------------------------------------------------------------------------------------------------------------------------------------------------------------------------------------------------------------------

- 5 Connect the interface cable between the DMA and the GCA using the appropriate ports for your configuration as shown in the table below. See the appropriate figures below. (NOTE: The labeling of the GCA ports on the top section of your unit may vary slightly from the figure shown.)

**Table 3: DMA/GCA Port Connections**

DMA Model	DMA Port	GCA Port
Q800 2980	COM 2 Cooling Accessory	ACCESSORY/COM B INSTRUMENT/COM A

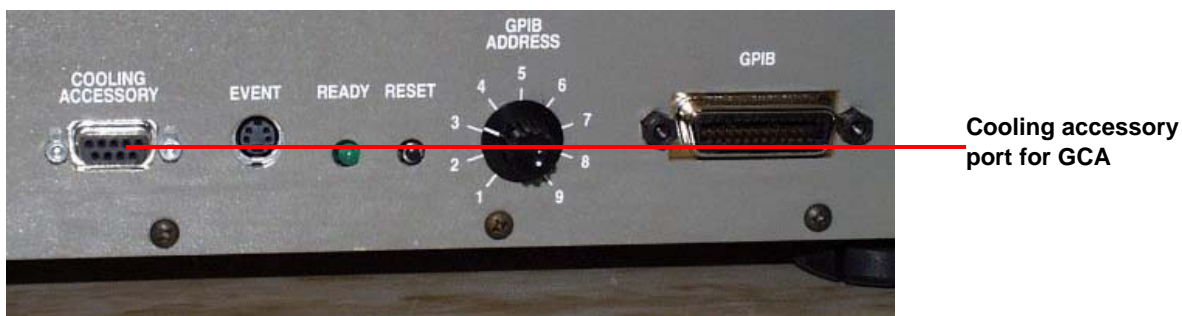


**Figure 9** GCA ports.



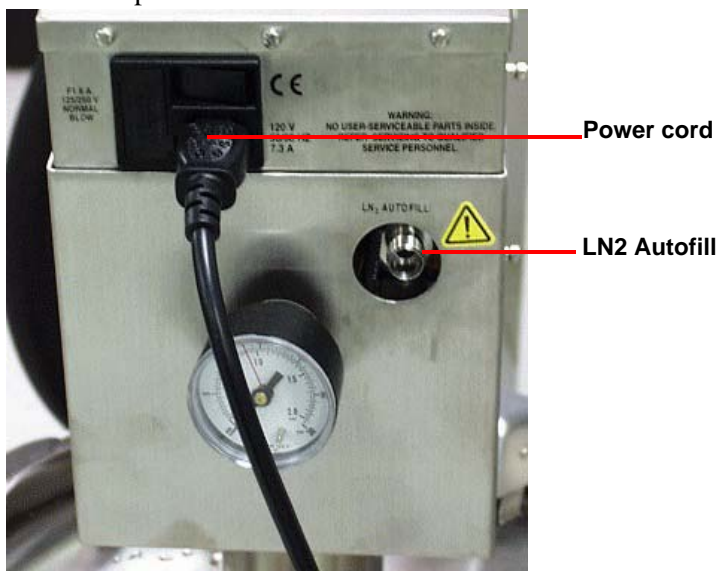
**Figure 10** DMA Q800 ports on left rear.





**Figure 11** DMA 2980 ports on right rear.

- 6 Attach the power cable to the back of the GCA.



**Figure 12** Power cord connected.

- 7 For the DMA Q800: Plug the power cable into the accessory outlet on the back of the DMA.  
For the DMA 2980: Plug the power cable into a 120 Vac power source.

- 8 Turn the power switch to the ON position. When the ready light glows, the accessory is ready to be used.

The GCA is designed to be filled automatically from a *low pressure*, 140 to 170 kPa gauge (20 to 25 psig), bulk storage liquid nitrogen container.

If you will not be using the autofill feature, turn to [Chapter 3](#) for manual filling instructions.

To use the auto refill capability, follow the next several steps.

**CAUTION:** If your liquid nitrogen source has more than 170 kPa gauge (25 psig), then a pressure regulator must be added to insure no more than 170 kPa gauge (25 psig) is delivered to the GCA. Failure to limit the pressure may result in damage to the fill solenoid valve, cause excessive fill times, and cause the safety pressure relief valve to activate.

**MISE EN GARDE:** Si la source de votre azote liquide a une pression manométrique supérieure à 170 kPa (25 psig), alors vous devez ajouter un régulateur de pression pour vous assurer que la pression manométrique fournie au GCA ne dépasse pas 170 kPa (25 psig). Le non respect de cette limitation de pression peut endommager l'électrovanne de remplissage, prolonger à l'excès la durée de remplissage et provoquer l'activation de la soupape de détente de pression.

- 9 Arrange the low pressure bulk storage source physically close enough, within 1.8 meters (6 feet), to the GCA so that the autofill hose can be easily connected between the source and the GCA. Likewise the GCA and the instrument need to be in close proximity to allow connection of the control cable and the 1.8-meter (6-foot) coolant transfer hose.
- 10 Attach the bulk storage feed hose to the GCA at the connection labeled **LN<sub>2</sub> Autofill** as shown in [Figure 12](#) above. Use a wrench to tighten the connector.
- 11 Attach the other end of the bulk storage feed hose assembly to the liquid feed connector on the bulk storage container.



**Figure 13** GCA attached to DMA Q800 (bulk source not shown).

## Updating the GCA Software with the DMA

The software used to run the GCA has already been loaded at TA Instruments. However, you may need to update that software with a new version. Follow the instructions in the DMA online help to update the GCA program.

Turn to [Chapter 3](#) for the instructions needed to fill the accessory with liquid nitrogen.

## Installing the GCA for use with the DHR or AR Rheometer EHP System

The GCA can be used in conjunction with the Electrically Heated Plates (EHP) accessory on the DHR Series or AR-G2/2000ex/1500ex to provide cooling down to  $-70^{\circ}\text{C}$ . Follow the instructions below to install the GCA.

- 1 Position the GCA within 1.8 meters (6 feet) of the instrument.
- 2 Attach the coolant transfer hose to the GCA at the fitting labeled **N<sub>2</sub> Gas to Instrument/LN<sub>2</sub> Manual Fill**.



**Figure 14** Coolant hose attached to fitting.

- 3 Remove the crash cool air lines to the EHP (if present), and attach a short coolant transfer hose to the upper and lower coolant inlets as shown in the figure below. Make sure the fittings are tight.




**Figure 15** Coolant transfer hose connected to upper and lower coolant inlets.

- 4 Connect the other ends of the short coolant transfer hoses and the main transfer hose from the GCA to the T-piece, as shown in the figure below. To avoid frosting during use, the T-piece can be insulated with pipe wrap. Connect the 8-mm FEP tubing to the upper EHP cooling exit pipe. This is required to match the back pressure of the upper cooling circuit to the lower, and also acts as an exhaust muffler.



**Figure 16** T-piece.

- 5 Make sure the power switch on the GCA is in the OFF position.

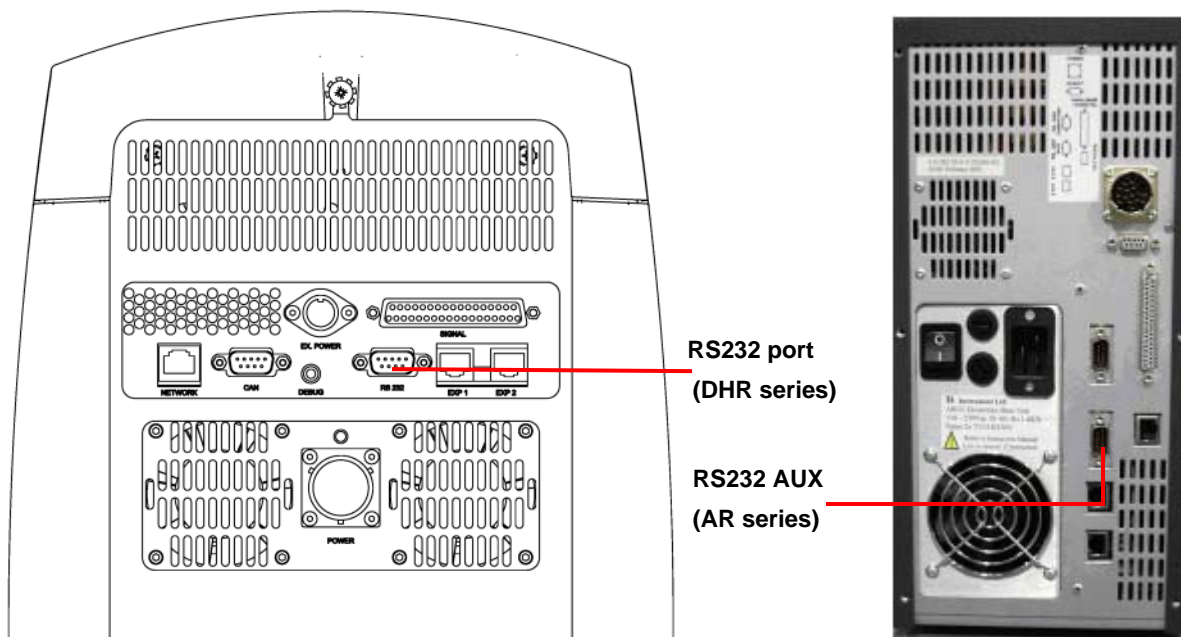


**WARNING: The instrument power switch should be OFF before connections are made.**

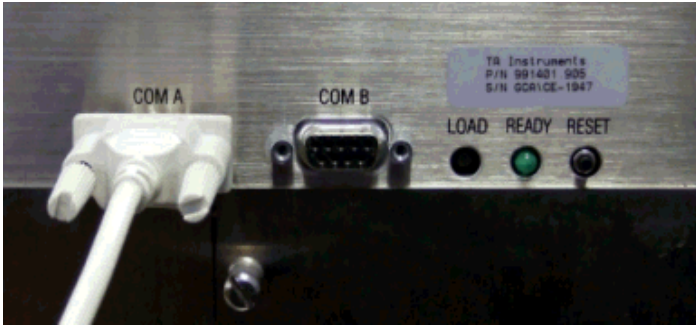
**AVERTISSEMENT: Avant d'effectuer les raccordements, l'interrupteur d'alimentation de l'instrument doit être à l'arrêt.**

- 6 Connect the interface cable supplied with the EHP cooling kit between COM A on the GCA and RS232 AUX (for AR series) or RS232 (for DHR series) on the rheometer electronics box. See [Figure 17](#) and [Figure 18](#) below.

**NOTE:** Do not use the interface cable supplied with the GCA.



**Figure 17** Electronics box back panel (DHR series, left; AR series, right).



**Figure 18** GCA ports.

- 7 Attach the power cable to the back of the GCA.



**Figure 19** Power cable attached.

- 8 Plug the power cable into a 120 Vac power source.
- 9 Turn the power switch to the ON position. When the ready light glows, the accessory is ready to be used.

The GCA is designed to be filled automatically from a low pressure, 140 to 170 kPa gauge (20 to 25 psig), bulk storage liquid nitrogen container.

If you will not be using the autofill feature, turn to [Chapter 3](#) for manual filling instructions.

To use the auto refill capability, follow the next several steps.

**CAUTION: If your liquid nitrogen source has more than 170 kPa gauge (25 psig), then a pressure regulator must be added to insure no more than 170 kPa gauge (25 psig) is delivered to the GCA. Failure to limit the pressure may result in damage to the fill solenoid valve, cause excessive fill times, and cause the safety pressure relief valve to activate.**

**MISE EN GARDE: Si la source de votre azote liquide a une pression manométrique supérieure à 170 kPa (25 psig), alors vous devez ajouter un régulateur de pression pour vous assurer que la pression manométrique fournie au GCA ne dépasse pas 170 kPa (25 psig). Le non respect de cette limitation de pression peut endommager l'électrovanne de remplissage, prolonger à l'excès la durée de remplissage et provoquer l'activation de la soupape de détente de pression.**

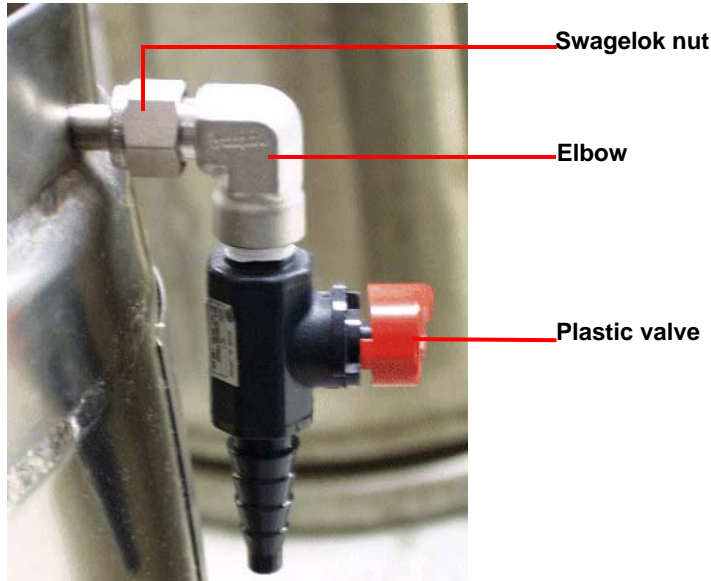
- 10** Arrange the low pressure bulk storage source physically close enough, within 1.8 meters (6 feet), to the GCA so that the autofill hose can be easily connected between the source and the GCA. Likewise the GCA and the instrument need to be in close proximity to allow connection of the control cable and the 1.8-meter (6-foot) coolant transfer hose.
- 11** Attach the bulk storage feed hose to the GCA at the connection labeled **LN<sub>2</sub> Autofill** as shown in [Figure 12](#). Use a wrench to tighten the connector.
- 12** Attach the other end of the bulk storage feed hose assembly to the liquid feed connector on the bulk storage container.

Turn to the next chapter for the instructions needed to fill the accessory with liquid nitrogen.

## Installing the Drain Valve

Ice and frost are created during normal use of the Gas Cooling Accessory. The GCA catch trough is designed to prevent water from dripping onto the floor creating a potential hazard when the ice and frost melt.

The drain valve may be needed to occasionally empty water from the catch trough. To install the condensate drain valve, use a 5/8-inch wrench on the Swagelok® nut, screw the elbow into the fitting until it is hand tight with the valve pointing down.



**Figure 20** GCA condensate drain valve.

Empty the GCA catch trough periodically by opening the valve and draining the water into a suitable container, or a hose can be connected to the valve and routed to a floor drain or large container.

**CAUTION: During manual filling operations, do not over fill the GCA tank causing liquid nitrogen to spill into the catch trough.**

**MISE EN GARDE: Pendant les opérations de remplissage manuel, ne remplissez pas trop le réservoir GCA de manière à provoquer le déversement de l'azote liquide dans la cuvette de récupération.**

# Chapter 3:

## Operating and Maintaining the GCA

---

### Overview

The GCA tank must be filled with liquid nitrogen before it can be used for cooling experiments with the DMA. There are two methods you can use to fill the GCA, depending on your laboratory setup:

- If you have the available space and are able to keep a bulk storage reservoir near the instrument, you can use the autofill feature. This allows you to automatically refill the GCA with liquid nitrogen from your bulk storage reservoir, when the GCA is not actively cooling.
- If you must take the GCA to the bulk storage reservoir for refilling, you will need to use the manual method to fill the GCA tank with liquid nitrogen.

Refer to the appropriate section in this chapter for the method of filling desired.



**WARNING: Read the safety precautions for handling cryogenic materials (located in the prefix of this manual) before filling the GCA. Wear goggles or a face shield and gloves large enough to be removed easily whenever you handle liquid nitrogen.**

**AVERTISSEMENT: Lisez les précautions de sécurité à prendre lors de la manipulation des matières cryogéniques (disponibles dans le préfixe du présent manuel avant d'installer le GCA. Portez des lunettes de protection ou un écran facial et des gants assez grands pour être retirés facilement chaque fois que vous manipulez de l'azote liquide.**

This chapter also includes guidelines on when to use the GCA with your DMA instrument and basic operation of the GCA.

### Autofilling the GCA

Autofilling refers to the automatic refilling of the GCA from the bulk storage tank, providing a readily available cooling source for experiments. This section tells you how to set up the GCA and the connected instrument to allow autofilling. See page 32 for information on manually filling the GCA.

The autofill feature ensures that a ready supply of liquid nitrogen is available for subambient experiments as well as reducing the time and effort that is involved with manual filling of the GCA. The following is a list of features associated with autofilling:

- It allows the bulk storage supply of liquid nitrogen to automatically refill the GCA on demand from the instrument.
- Typical fill times for automatic refilling will be approximately 20 minutes, if the tank is completely empty. The time for automatic refilling is much shorter (about 10 minutes), if there is any liquid nitrogen left in the tank.



- Any autofill cycle will automatically stop if a test is started on the instrument. Autofill can only occur when a method is not in progress.

For information on running subambient experiments refer to the appropriate topic on the DMA Q800 online help or to the appropriate chapter in the online *DMA 2980 Operator's Manual*.

## Autofilling the GCA for the First Time (DMA)

The GCA must be filled before cooling experiments can be performed on the DMA. When you have completely installed the GCA, as directed in Chapter 2, and are ready to use the autofill system, follow these steps:

- 1 Open the liquid feed valve on the low pressure [170 kPa gauge (25 psig) maximum] bulk storage container. Do not close this valve again until the bulk storage container is empty, or wait until 15 minutes after the fill sequence has been completed.
- 2 Select **Control/GCA fill** on the instrument control menu, or select the GCA Fill icon on the tool bar, or press GCA on the DMA Q800 touch screen to start the automatic filling process.

The autofill will shut off when the dewar is full, the bulk storage tank is empty, or the GCA tank pressure is below one psig for more than one minute.

**NOTE:** Cold gas will escape from the GCA vent valve and may escape from the relief valve under certain filling conditions. The fill process normally takes about 20 minutes.

**NOTE:** Frost will build up on the tubing and parts of the GCA and storage tank while the liquid nitrogen is being transferred. The insulation on the bulk storage feed tube will become stiff and brittle during the autofill process. Allow the tube to return to room temperature before attempting to move or bend the tube.

## Refilling the GCA After a DMA Experiment

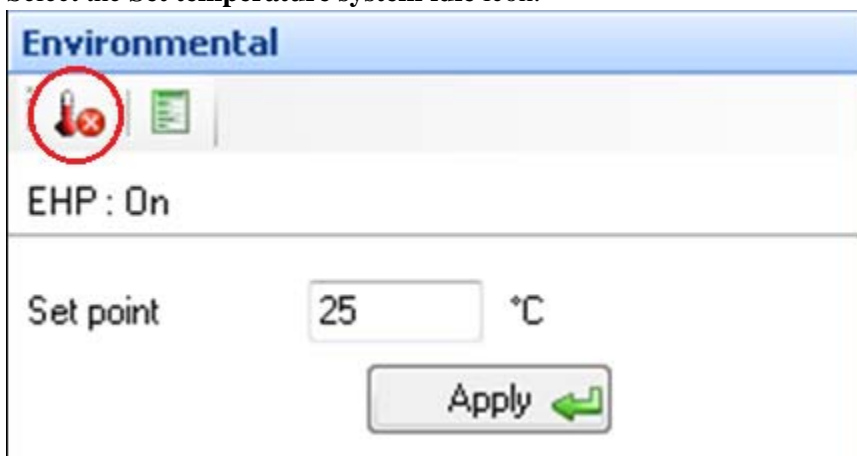
To automatically refill the GCA with liquid nitrogen after an experiment is completed, you simply set the **Post Test** conditions to select autofilling at the end of a method.

## Autofilling the GCA for the First Time (Rheometer)

The GCA must be filled before cooling experiments can be performed on the rheometer with the EHP installed. When you have completely installed the GCA, as directed in [Chapter 2](#), and are ready to use the autofill system, follow these steps:

- 1 Open the liquid feed valve on the low pressure [170 kPa gauge (25 psig) maximum] bulk storage container. Do not close this valve again until the bulk storage container is empty, or wait until 15 minutes after the fill sequence has been completed.

- 2 Select the **Set temperature system idle** icon.



**Figure 21** Select Set temperature system idle.

**NOTE:** An autofill will also be initiated when the GCA is first powered on.

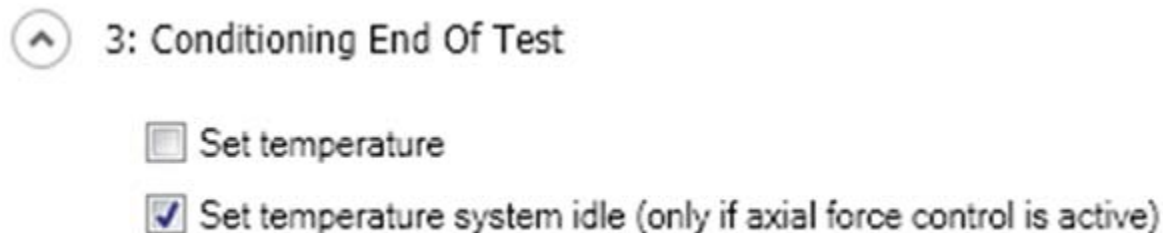
- 3 The autofill will shut off when the temperature system is activated by starting an experiment or setting a temperature on the status page, the dewar is full, the bulk storage tank is empty, or the GCA tank pressure is below one psig for more than one minute.

**NOTE:** Cold gas will escape from the GCA vent valve and may escape from the relief valve under certain filling conditions. The fill process normally takes about 20 minutes.

**NOTE:** Frost will build up on the tubing and parts of the GCA and storage tank while the liquid nitrogen is being transferred. The insulation on the bulk storage feed tube will become stiff and brittle during the autofill process. Allow the tube to return to room temperature before attempting to move or bend the tube.

## Refilling the GCA after a Rheometer Experiment

To automatically refill the GCA with liquid nitrogen after an experiment is completed, select **Set temperature system idle** in the procedure post experiment step as shown in the figure below. If normal force control is not active in your experiment, it will necessary to manually activate the fill by selecting **Set temperature system idle** from the **Environmental** control panel.



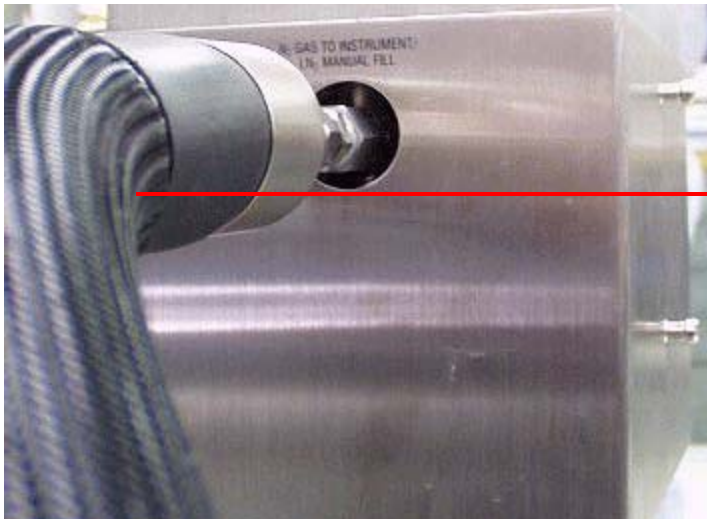
**Figure 22** Set temperature system idle.

## Manually Filling the GCA

The GCA is designed so that it can be filled manually as well as automatically. The automatic filling procedure has been discussed previously. The instructions found in this section explain the method used to manually fill the GCA. The manual fill mode should only be used when a bulk storage reservoir cannot be placed close to the GCA. Follow the directions below to fill the GCA manually.

**NOTE:** Adapters, which are not supplied, may be required.

- 1 Make sure that the bulk storage source that will be used for filling the GCA is a low pressure [170 kPa gauge (25 psig) maximum] container. Use a regulator if the pressure is greater than 170 kPa gauge (25 psig).
- 2 Turn off the POWER switch on the GCA and disconnect the power cable.
- 3 Disconnect the interface cable from the GCA. (See page 24 to determine the port used for your unit.)
- 4 Use a wrench to disconnect the coolant transfer hose from the GCA. This is the hose, shown in the figure below, which runs from the GCA to the instrument.



**Remove this coolant transfer hose when manually filling the GCA. The bulk storage feed hose will be used here instead.**

**Figure 23** Disconnect the coolant transfer hose.

- 5 Wheel the GCA to your bulk storage reservoir location.
- 6 Connect the bulk storage feed hose from the bulk storage reservoir to the **N<sub>2</sub> Gas to Instrument/LN<sub>2</sub> Manual Fill** fitting on the GCA (shown in [Figure 23](#)). Tighten all fittings.
- 7 Open the valve on the bulk storage reservoir and begin filling the GCA.

**NOTE:** Cold gas will escape from the GCA vent valve and may escape from the relief valve under certain filling conditions. The fill process normally takes about 20 minutes.

**NOTE:** Frost will build up on the tubing and parts of the GCA and storage tank while the liquid nitrogen is being transferred. The insulation on the bulk storage feed tube will become stiff and brittle during the auto-fill process. Allow the tube to return to room temperature before attempting to move or bend the tube.

- 8 Fill the GCA with liquid nitrogen until it weighs 175 lbs. The tank will be about three-quarters full.

**NOTE:** If the GCA is overfilled, the excess liquid nitrogen will automatically be boiled off when the GCA is connected to the instrument.

- 9 Close the valve on the bulk storage reservoir. Allow time for the liquid within the transfer hose to evaporate (approximately 15 minutes).
- 10 Disconnect the feed hose from the GCA.

**CAUTION: Use care when wheeling the full GCA to another location. The agitation will cause increased venting of the liquid nitrogen, and it may tip over easily.**

**MISE EN GARDE: Soyez prudent lors du déplacement du GCA plein vers un autre emplacement. L'agitation fait augmenter l'évacuation de l'azote liquide et le GCA peut basculer facilement.**

- 11 Wheel the GCA back to the instrument and reconnect the coolant transfer hose from the instrument to the GCA.
- 12 Reconnect the interface cable from the instrument to the GCA. (See page 24 to determine the port used for your unit.)
- 13 Turn on the POWER switch. The GCA is ready to operate.

## Operating Your GCA with the DMA

During experiments the DMA monitors the need for coolant and automatically communicates the need for the power to the GCA heaters. This enables the variation of the coolant flow, as needed, to obtain the set temperature required in your experiments.

The Gas Cooling Accessory is generally used with the TA Instruments DMA in the following situations:

- When a subambient heating segment is used that is slower than the intrinsic heating rate of the furnace (which is approximately 2-3°C/min.).
- When any cooling segment is used in a method.
- When an isothermal segment is used at a temperature below 100°C.

Even if you are not using the GCA for cooling, it will still be active so that the normal boil-off of the gas from the tank will purge the furnace and sample with dry nitrogen.

### Basic Operation

Follow these basic steps to use the GCA with the DMA.

- 1 Connect and fill the GCA as directed in this manual.
- 2 Mount the sample in the DMA clamp. See the appropriate documentation for instructions if needed.
- 3 Make sure the DMA power, DMA heater, and GCA power switches are switched on.
- 4 Use the instrument control software to set up and start your experiment.

**NOTE:** If you are starting your experiment at a subambient temperature, you may want to retighten the clamp at the lower temperature before beginning your run, depending on the clamp type. See the online help for details to perform this step.

### Maintaining the GCA

The primary maintenance procedures described in this section are the customer's responsibility. Any further maintenance should be performed by a representative of TA Instruments or other qualified service personnel. Consult the online documentation installed with the instrument control software for further information.



**WARNING: Because of the high voltages in this instrument, untrained personnel must not attempt to test or repair any electrical circuits.**

**AVERTISSEMENT: À cause de la présence de tensions élevées dans cet instrument, le personnel non formé ne doit pas essayer de tester ou de réparer les circuits électriques.**

The Gas Cooling Accessory actually requires very little maintenance. The following items may need attention and are covered in this section:

- Cleaning
- Fuse replacement

## Cleaning the GCA

You can clean the GCA as often as you like. The unit should be cleaned with a household liquid glass cleaner and soft cloth. Wet the cloth, not the unit with the glass cleaner, and then wipe off the unit and surrounding surfaces.



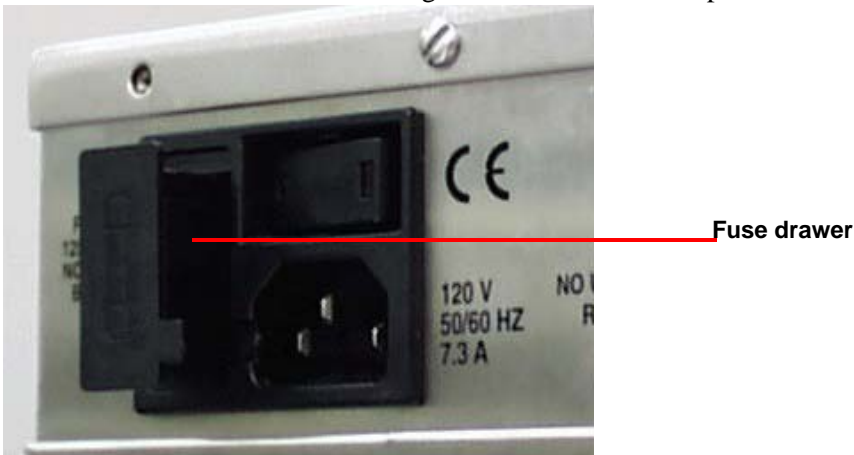
**WARNING: Do not use harsh chemicals, abrasive cleansers, steel wool, or any rough materials to clean the unit.**

**AVERTISSEMENT: N'utilisez pas de produits chimiques agressifs, de nettoyeurs abrasifs, de la laine d'acier ou tout autre matériau rugueux pour nettoyer l'appareil.**

## Replacing the Fuses

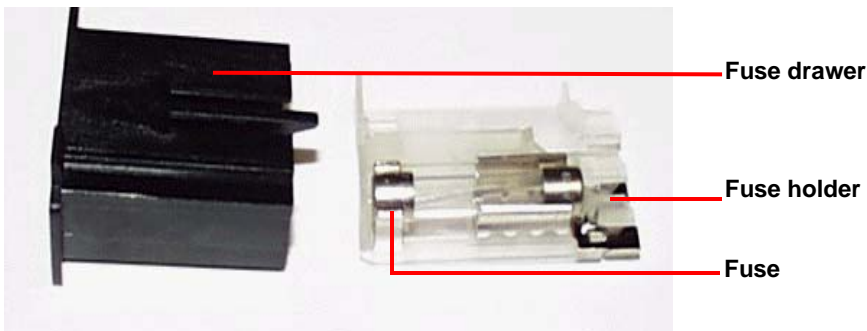
You can replace the fuses found in the power entry module located on the rear of the electronics control box. To check or change these fuses follow the instructions below and refer to the figures as needed:

- 1 Turn the cooling accessory off and remove the power cord.
- 2 Insert a small screwdriver on the edge of the fuse drawer to pull it out of the instrument.



**Figure 24** Fuse drawer.

- 3 Slide the fuse holder out of the fuse drawer.



**Figure 25** Fuse drawer with fuse and fuse holder.

- 4 Remove the old fuse and replace the fuse only with the type and rating indicated on the instrument's rear panel.
- 5 Place fuse holder back into the fuse drawer and slide the drawer into the opening.
- 6 Replace the power cord and turn the unit back on.

## Replacement Parts

Service should only be performed by qualified service personnel. Please contact TA Instruments at one of the offices listed in the TA Manual Supplement. See the link on page 3 for information. To ensure that you receive the correct part for your unit, be sure to include the part number, description, instrument type, model number, and serial number.

**Table 4: GCA Parts List**

Part No.	Description
264064.001	Gasket, Neoprene Tank, 8 cm (3 inch) diameter, GCA
991075.902	Tank, GCA Replacement
200171.013	Fuse
991441.001	GCA/Bulk Supply LN <sub>2</sub> Transfer Line
991442.001	DMA/GCA LN <sub>2</sub> Transfer Line
270712.001	Cable, RS232
890035.901	Power Cord (DMA 2980)
271607.001	Power Cord (DMA Q800)

# Index

## C

cautions 4  
cleaning 35  
components 15

## E

electromagnetic compatibility standards 4  
electronics box 27

## F

filling the GCA 30

## G

### GCA

cleaning 35  
maintaining 34  
operating with DMA 34  
parts 17  
ports 15, 16  
replacement parts 36  
replacing fuses 35

### GCA tank

autofill 30  
manual filling 32  
refilling 31

## I

### installation

AR 24  
checks before 19  
choosing a location 19  
DHR 24  
DMA 20



drain valve 28

instrument symbols 5

## L

license agreement 3

## M

maintenance 34

    cleaning 35

    replacement parts 36

    replacing fuses 35

## N

notes 4

## O

operation

    DMA 34

    theory 14

overview 12

## P

Partitioned Plate

    overview 12

patents 3

## R

regulatory compliance 4

replacement parts 36

replacing fuses 35

RS232 port 27

## S

safety 5

- accessory symbols 6
- instrument symbols 5
- required equipment 5

safety standards 4

software

- updating 24

## T

TA Instruments offices 3

trademarks 3

## W

warnings 4